

Basic version for milling machine tools

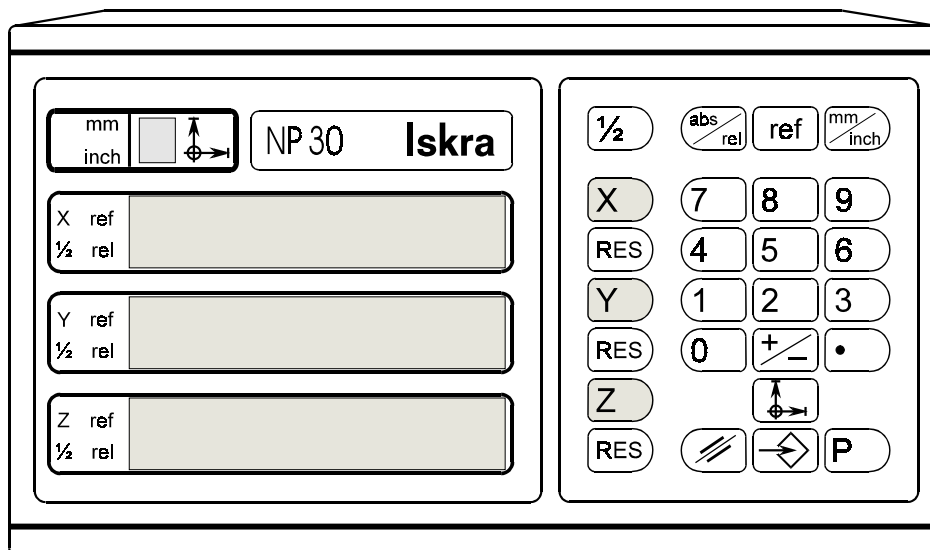

X Y Z	axis selection keys	ref	reference point mode
RES	reset key of absolute position		measuring relative to datum points
	measuring of relative position		delete
	mm/inch measuring		enter
"	halving of positioning value	0 ... 9	numeric value selection keys
P	parameter entry		

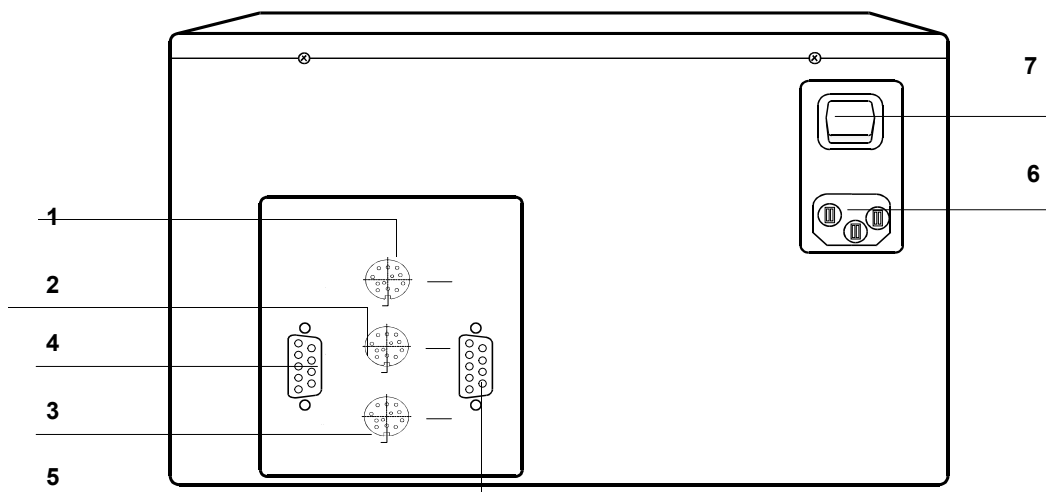

1	connector for X axis
2	connector for Y axis
3	connector for Z axis
4	RIE
5	RS232C
6	plug for main supply voltage
7	power ON/OFF switch

The drawing refers to "S" (box) and "P" (panel) version.
For "C" (console) and "T" (table-top) see pages: 109-110.

Basic version for milling machine tools

GENERAL DESCRIPTION AND FUNCTIONS:

The position readout device NP30 is used in conjunction with different incremental transducers (linear scales, rotary encoders) as a system for measuring position and length on milling machine tools.

The microcomputer based structure guarantees high operating reliability while software enables the introduction of additional new functions in order to simplify operation and to adapt the device to users.

FUNCTIONS:

q Reset	q abs/rel measuring	q 9 Datum points
q Preset	q Inch/mm measuring	q Machine tool error compensation
q Reference pont	q Halving of positioning value	q Parameter entry and display
q Velocity measuring	q Bolt hole positioning	

OPTIONS:

q RS 232 C	q Built-in sine current interpolation	q Baterry back-up
------------	---------------------------------------	-------------------

TECHNICAL DATA:

Supply voltage special order:	220 V +10% -15%, 110V +10% -15% 80 - 250 VAC
Supply voltage frequency	48 Hz - 62 Hz
Power consumption	cca 20 VA
Operating temperature	0 - 45°C
Relative humidity	5 - 75%
Mechanical protection	IP 42
Vibrations	1 g from 10 to 150 Hz
Shocks	15 g
EMC:	
Immunity	EN 50 082/2
Emission	EN 50 081/1
Dimensions	W x H x D = 250 x 150 x 101 mm
Weight	1.5 kg

MEASURING SIGNALS:

Input signals - square-wave inverted signals (DI, DS):

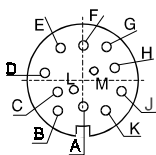

Supply voltage	5 V (from device)
Max. frequency	1 Mhz
Connector	12 pole, Amphenol

Axis X, Y, Z	contact	A	B	C	D	E	G	H	K	L
	signal	shield	0V	A	\bar{A}	B	RI	\bar{RI}	+V	\bar{B}

Basic version for milling machine tools

MEASURING SIGNALS:

Input signals - sine-wave current signals (SI - option, available on special request):

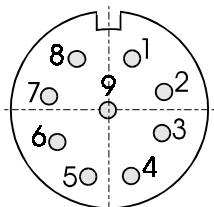

Supply voltage	5 V
Max. frequency	50 KHz
Connector	9 pole, Contact
Amplitude of measuring signals	7 to 16 μ App (1 kOhm)
Amplitude of ref. signal	2 to 8 μ App (1 kOhm)

Axis X, Y, Z

pin	1	2	3	4	5	6	7	8	9
signal	I _a ⁺	I _a ⁻	+5 V	0 V	I _b ⁺	I _b ⁻	I _r ⁺	I _r ⁻	shield

CONNECTOR FOR RIE:

pin	1	2	3	4	5	6	7	8	9
signal	input RIE _X	input RIE _Y	input RIE _Z	-	+5V	-	-	-	-

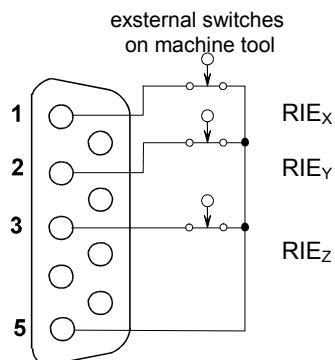

Remark:

The RIE connector is used in the case of using rotary encoders as measuring transducers. A rotary encoder emits one reference pulse at each turn of the axis, therefore, a selection switch RIE has to be mounted on the machine tool for each axis.

This switch allows only one of many reference pulses in a whole measuring range to reach the readout device for calibrating purposes. The pulse is enabled when the switch is open.

CONNECTOR FOR RS 232 C:

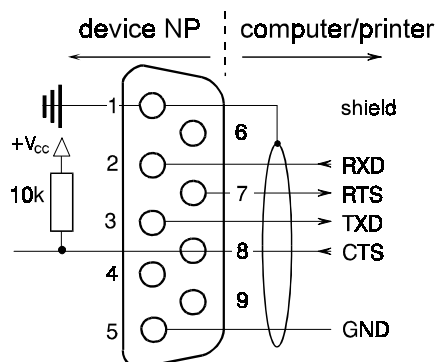

pin	1	2	3	4	5	6	7	8	9
signal	shield	RXD	TXD	-	GND	-	RTS	CTS	-

DIGITAL POSITION READOUT SYSTEM

NP30

Basic version for milling machine tools

STANDARD DELIVERY:

Digital readout system NP 30.

Power supply cable with plug-in connector for 220 VAC, 50 Hz, 3 m length.

Spare fuse 0.2 AT for 220 VAC, or 0.4 AT for 110 VAC.

DIMENSIONS:

For dimensions of different housing types see :

"HOUSING TYPES S, P, C and T"

pages 109-110.

OPTIONS:

All devices can be delivered with the following options:

SI	Sine current measuring input signals with interpolation electronics (on special request)
B	Battery back-up
R	RIE connector
K	RS232C serial interface

ACCESSORIES:

For "S" - box version: stand D
For "C" - console version: console from 15 cm to 45 cm
For details see pages: 109-110

ORDERING DATA:

Standard delivery:				Options:			
NP 30	Housing	Input measuring signals	Power supply	B	K	TS	R
	S = Box C* = Console T = Table top P = Panel C* = In case of console DRO's ordering it is required to order separately Console itself (available lengths from 15 cm to 45	DS = 5V TTL (standard RS422A) SI = 11 μ A (option on request)	SM = Switch Mode: universal power supply 85-250V (standard for C , T and P version) LM = Linear Mode: standard for S version) LM1 : 110VAC LM2 : 220VAC	Battery back up	Communication interface RS232C	Touch sensor	RIE External switch (in case of rotary encoder)

Iskra Tela d.d.

Savska cesta 3, 1000 Ljubljana, SLOVENIA
Phone: ++386-1-4733196, Fax: +386-1-4375516
E-Mail: info@iskra-tela.si, www.iskra-tela.si